

**FEATURES**

- ▶ Fully Encapsulated Plastic Case for Chassis and DIN-Rail Mounting Version
- ▶ Ultra-wide 4:1 Input Voltage Range
- ▶ Fully Regulated Output Voltage
- ▶ Excellent Efficiency up to 91%
- ▶ I/O Isolation 2500 VDC
- ▶ Operating Temp. Range -40°C to +90°C
- ▶ Overload /Voltage and Short Circuit Protection
- ▶ Remote On/Off Control
- ▶ Conducted EMI meet EN55022 Class A & FCC Level A
- ▶ EMC Immunity meet EN61000-4-2,3,4,5,6,8
- ▶ UL/cUL/IEC/EN 60950-1 Safety Approval & CE Marking

**NEW**

**PRODUCT OVERVIEW**

The MINMAX MOWI20C series is a new range of regulated DC/DC converter modules with ultra-wide 4:1 input voltage ranges. The product comes in a fully encapsulated module with screw terminal block and is suitable for easy chassis mounting or also for DIN-rail mounting.

Featuring an extended operating temperature range from -40°C to +90°C, EMC compliance to EN 61000-6-1 standard these modules have been designed particularly for industrial applications.

**Model Selection Guide**

| Model Number   | Input Voltage (Range)<br>VDC | Output Voltage<br>VDC | Output Current<br>Max.<br>mA | Input Current           |                       | Max. capacitive Load<br>μF | Efficiency (typ.)<br>@Max. Load<br>% |
|----------------|------------------------------|-----------------------|------------------------------|-------------------------|-----------------------|----------------------------|--------------------------------------|
|                |                              |                       |                              | @ Max. Load<br>mA(typ.) | @ No Load<br>mA(typ.) |                            |                                      |
| MOWI20-24S051C | 24<br>(9 ~ 36)               | 5.1                   | 4000                         | 944                     | 70                    | 6800                       | 90                                   |
| MOWI20-24S12C  |                              | 12                    | 1670                         | 918                     | 70                    | 1160                       | 91                                   |
| MOWI20-24S24C  |                              | 24                    | 835                          | 918                     | 70                    | 300                        | 91                                   |
| MOWI20-24S48C  |                              | 48                    | 420                          | 944                     | 70                    | 75                         | 89                                   |
| MOWI20-48S051C | 48<br>(18 ~ 75)              | 5.1                   | 4000                         | 472                     | 35                    | 6800                       | 90                                   |
| MOWI20-48S12C  |                              | 12                    | 1670                         | 459                     | 35                    | 1160                       | 91                                   |
| MOWI20-48S24C  |                              | 24                    | 835                          | 459                     | 35                    | 300                        | 91                                   |
| MOWI20-48S48C  |                              | 48                    | 420                          | 472                     | 35                    | 75                         | 89                                   |

**Input Specifications**

| Parameter                         | Model            | Min.                                    | Typ. | Max. | Unit |
|-----------------------------------|------------------|---|------|------|------|
| Input Surge Voltage (100 ms max.) | 24V Input Models | -0.7                                    | ---  | 50   | VDC  |
|                                   | 48V Input Models | -0.7                                    | ---  | 100  |      |
| Start-Up Threshold Voltage        | 24V Input Models | ---                                     | ---  | 9    |      |
|                                   | 48V Input Models | ---                                     | ---  | 18   |      |
| Under Voltage Shutdown            | 24V Input Models | ---                                     | 7.5  | ---  |      |
|                                   | 48V Input Models | ---                                     | 16   | ---  |      |
| Start Up Time                     | Power Up         | ---                                     | ---  | 30   | ms   |
|                                   | Remote On/Off    | Nominal Vin and Constant Resistive Load |      | 30   | ms   |
| Input Filter                      | All Models       | Internal Pi Type                        |      |      |      |

**Remote On/Off Control**

| Parameter                   | Conditions                   | Min.                       | Typ. | Max. | Unit |
|-----------------------------|------------------------------|----------------------------|------|------|------|
| Converter On                |                              | 3.5V ~ 12V or Open Circuit |      |      |      |
| Converter Off               |                              | 0V ~ 1.2V or Short Circuit |      |      |      |
| Control Input Current (On)  | Vctrl = 5.0V                 | ---                        | ---  | 0.5  | mA   |
| Control Input Current (Off) | Vctrl = 0V                   | ---                        | ---  | -0.5 | mA   |
| Control Common              | Referenced to Negative Input |                            |      |      |      |
| Standby Input Current       | Supply Off & Nominal Vin     | ---                        | 3    | ---  | mA   |

**Output Specifications**

| Parameter                       | Conditions  | Min.                    | Typ.  | Max. | Unit    |                   |
|---------------------------------|---|-------------------------|-------|------|---------|-------------------|
| Output Voltage Setting Accuracy |   | ---                     | ±2.0  | ---  | %Vnom.  |                   |
| Line Regulation                 | Vin=Min. to Max. @Full Load   | ---                     | ±0.5  | ---  | %       |                   |
| Load Regulation                 | Io=0% to 100%   | ---                     | ±0.5  | ---  | %       |                   |
| Minimum Load                    | No minimum Load Requirement   |                         |       |      |         |                   |
| Ripple & Noise                  | 0-20MHz bandwidth   | 5.1V Output Models      | ---   | ---  | 100     | mV <sub>P-P</sub> |
|                                 |   | 12V & 24V Output Models | ---   | ---  | 150     | mV <sub>P-P</sub> |
|                                 |   | 48V Output Models       | ---   | ---  | 200     | mV <sub>P-P</sub> |
| Transient Recovery Time         | 25% Load Step Change <sub>(2)</sub>   | ---                     | 250   | ---  | µsec    |                   |
| Transient Response Deviation    |   | ---                     | ±3    | ±5   | %       |                   |
| Over Voltage Protection         | Zener diode clamp   | ---                     | 120   | ---  | % of Vo |                   |
| Temperature Coefficient         |   | ---                     | ±0.02 | ---  | %/°C    |                   |
| Over Load Protection            | Current Limitation at 150% typ. of Iout max., Hiccup Mode, automatic recovery |                         |       |      |         |                   |
| Short Circuit Protection        | Hiccup Mode 0.25Hz typ, Automatic Recovery                                    |                         |       |      |         |                   |

**General Specifications**

| Parameter                 | Conditions   | Min.    | Typ. | Max. | Unit  |
|---------------------------|--|---------|------|------|-------|
| I/O Isolation Voltage     | 60 Seconds   | 2500    | ---  | ---  | VDC   |
| I/O Isolation Resistance  | 500 VDC  | 1000    | ---  | ---  | MΩ    |
| I/O Isolation Capacitance | 100KHz, 1V   | ---     | ---  | 2200 | pF    |
| Switching Frequency       |  | ---     | 285  | ---  | KHz   |
| MTBF (calculated)         | MIL-HDBK-217F@25°C, Ground Benign                                      | 775,200 |      |      | Hours |
| Safety Approvals          | UL/cUL 60950-1 recognition(UL certificate), IEC/EN 60950-1(CB- report) |         |      |      |       |

**Environmental Specifications**

| Parameter   | Conditions/Model       | Min. | Max. | Unit     |
|---|------------------------|------|------|----------|
| Operating Ambient Temperature Range<br>Natural Convection <sup>(6)</sup><br>Nominal Vin, Load 100% Inom.<br>(for Power Derating see relative Derating Curves) | MOWI20-24S12C,24S24C   | -40  | +87  | °C       |
|   | MOWI20-48S12C,48S24C   |      |      |          |
|   | MOWI20-24S051C,48S051C |      |      |          |
|   | MOWI20-24S48C,48S48C   |      |      |          |
| Thermal Impedance   | Natural Convection     | 3.9  | ---  | °C/W     |
|   | 100LFM Convection      | 3.3  | ---  | °C/W     |
|   | 200LFM Convection      | 3.1  | ---  | °C/W     |
|   | 400LFM Convection      | 2.5  | ---  | °C/W     |
| Case Temperature  |                        | ---  | +95  | °C       |
| Storage Temperature Range   |                        | -50  | +125 | °C       |
| Humidity (non condensing)   |                        | ---  | 95   | % rel. H |
| Cooling   | Natural Convection     |      |      |          |

**EMC Specifications**

| Parameter | Standards & Level  |   | Performance |
|-----------|--|---|-------------|
| EMI       | EMI Conducted Class A without adding any external components |   | Class A     |
|           | EMI Radiated Class A external components                     |   |             |
| EMS       | EN55024  |   | A           |
|           | ESD  | EN61000-4-2 Air $\pm 8kV$ , Contact $\pm 4kV$ |             |
|           | Radiated immunity  | EN61000-4-3 10V/m                             |             |
|           | Fast transient   | EN61000-4-4 $\pm 2kV$                         |             |
|           | Surge  | EN61000-4-5 $\pm 2kV$                         |             |
|           | Conducted immunity   | EN61000-4-6 10Vrms                            |             |
|           | PFMF   | EN61000-4-8 30A/M                             |             |

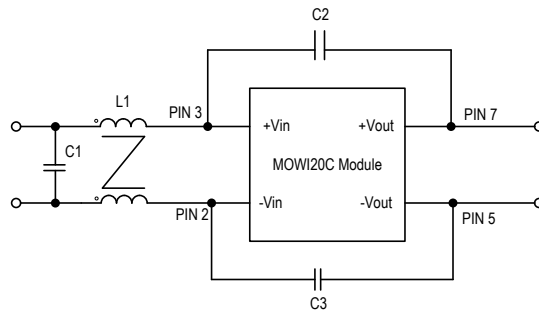
**External Filter meets Radiated EMI EN55022 class A; FCC part 15 level A**

| Model         | L1                      | C1               | C2    | C3    |
|---------------|-------------------------|------------------|-------|-------|
| MOWI20-24SXXC | 120 $\mu$ H/120 $\mu$ H | 4.7 $\mu$ F/50V  | None  | 220pF |
| MOWI20-48SXXC | 120 $\mu$ H/120 $\mu$ H | 3.3 $\mu$ F/100V | 220pF | 220pF |

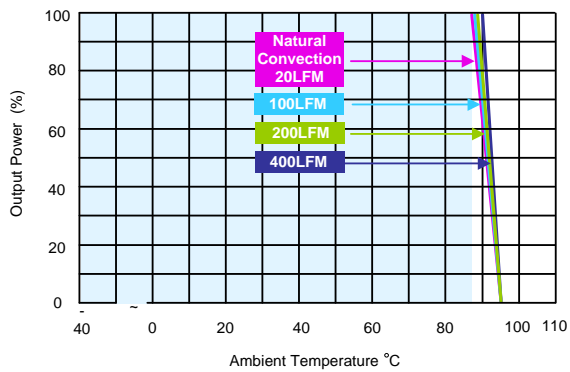
**Power Derating Curve**

MOWI20-24S12C, MOWI20-24S24C, MOWI20-48S12C, MOWI20-48S24C

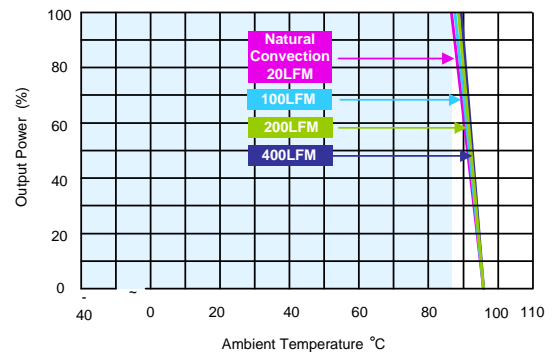

MOWI20-24S051C, MOWI20-48S051C

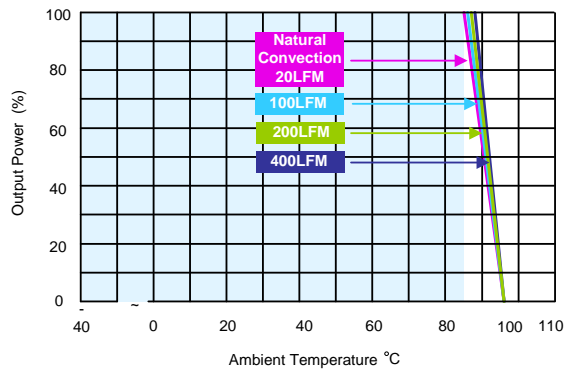

MOWI20-24S48C, MOWI20-48S48C

**Notes**

- 1 Specifications typical at Ta=+25°C, resistive load, nominal input voltage and rated output current unless otherwise noted.
- 2 Transient recovery time is measured to within 1% error band for a step change in output load of 75% to 100%.
- 3 We recommend to protect the converter by a slow blow fuse in the input supply line.
- 4 Other input and output voltage may be available, please contact factory.
- 5 That "natural convection" is about 20LFM but is not equal to still air (0 LFM)
- 6 Specifications are subject to change without notice.

**Package Specifications Chassis Mounting**

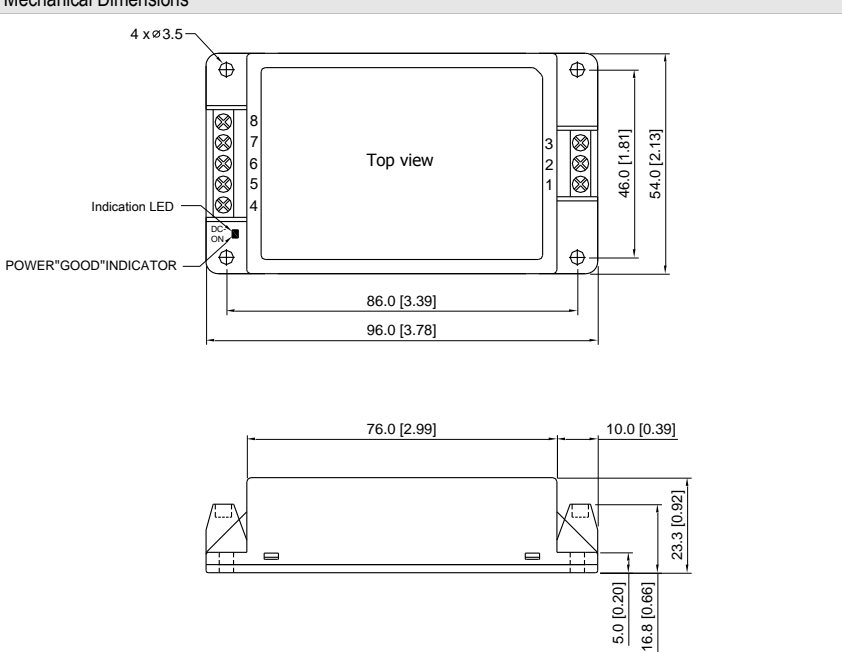
| Mechanical Dimensions   |               | Connections  |  |     |          |   |               |   |      |   |      |   |    |   |       |   |    |   |       |   |    |
|---|---------------|--|--|-----|----------|---|---------------|---|------|---|------|---|----|---|-------|---|----|---|-------|---|----|
|  <p>The drawing shows a top view and a side view of the module. The top view includes dimensions for the overall width (96.0 mm [3.78 inches]), the width of the main body (86.0 mm [3.39 inches]), and the width of the terminal block (46.0 mm [1.81 inches]). It also shows the height of the terminal block (54.0 mm [2.13 inches]) and the height of the main body (23.3 mm [0.92 inches]). The side view shows the mounting tabs with a height of 16.8 mm [0.66 inches] and a width of 5.0 mm [0.20 inches].</p> |               | <table border="1" style="width: 100%; border-collapse: collapse;"> <thead> <tr> <th style="width: 10%;">Pin</th> <th style="width: 90%;">Function</th> </tr> </thead> <tbody> <tr> <td>1</td> <td>Remote On/Off</td> </tr> <tr> <td>2</td> <td>-Vin</td> </tr> <tr> <td>3</td> <td>+Vin</td> </tr> <tr> <td>4</td> <td>NC</td> </tr> <tr> <td>5</td> <td>-Vout</td> </tr> <tr> <td>6</td> <td>NC</td> </tr> <tr> <td>7</td> <td>+Vout</td> </tr> <tr> <td>8</td> <td>NC</td> </tr> </tbody> </table> <p style="text-align: center;">NC: No Connection</p> <p>▶ All dimensions in mm (inches)<br/>▶ Tolerance: ±0.5 (±0.02)</p> |  | Pin | Function | 1 | Remote On/Off | 2 | -Vin | 3 | +Vin | 4 | NC | 5 | -Vout | 6 | NC | 7 | +Vout | 8 | NC |
| Pin   | Function      |  |  |     |          |   |               |   |      |   |      |   |    |   |       |   |    |   |       |   |    |
| 1   | Remote On/Off |  |  |     |          |   |               |   |      |   |      |   |    |   |       |   |    |   |       |   |    |
| 2   | -Vin          |  |  |     |          |   |               |   |      |   |      |   |    |   |       |   |    |   |       |   |    |
| 3   | +Vin          |  |  |     |          |   |               |   |      |   |      |   |    |   |       |   |    |   |       |   |    |
| 4   | NC            |  |  |     |          |   |               |   |      |   |      |   |    |   |       |   |    |   |       |   |    |
| 5   | -Vout         |  |  |     |          |   |               |   |      |   |      |   |    |   |       |   |    |   |       |   |    |
| 6   | NC            |  |  |     |          |   |               |   |      |   |      |   |    |   |       |   |    |   |       |   |    |
| 7   | +Vout         |  |  |     |          |   |               |   |      |   |      |   |    |   |       |   |    |   |       |   |    |
| 8   | NC            |  |  |     |          |   |               |   |      |   |      |   |    |   |       |   |    |   |       |   |    |

**Physical Characteristics**

|               |  |
|---------------|--|
| Case Size     | : 96.0x54.0x23.3mm (3.78x2.13x0.92 inches)       |
| Case Material | : Plastic resin (flammability to UL 94V-0 rated) |
| Weight        | : 107g   |

**Package Specifications with DIN Rail Mounting Bracket (order code AC-DIN-01)**

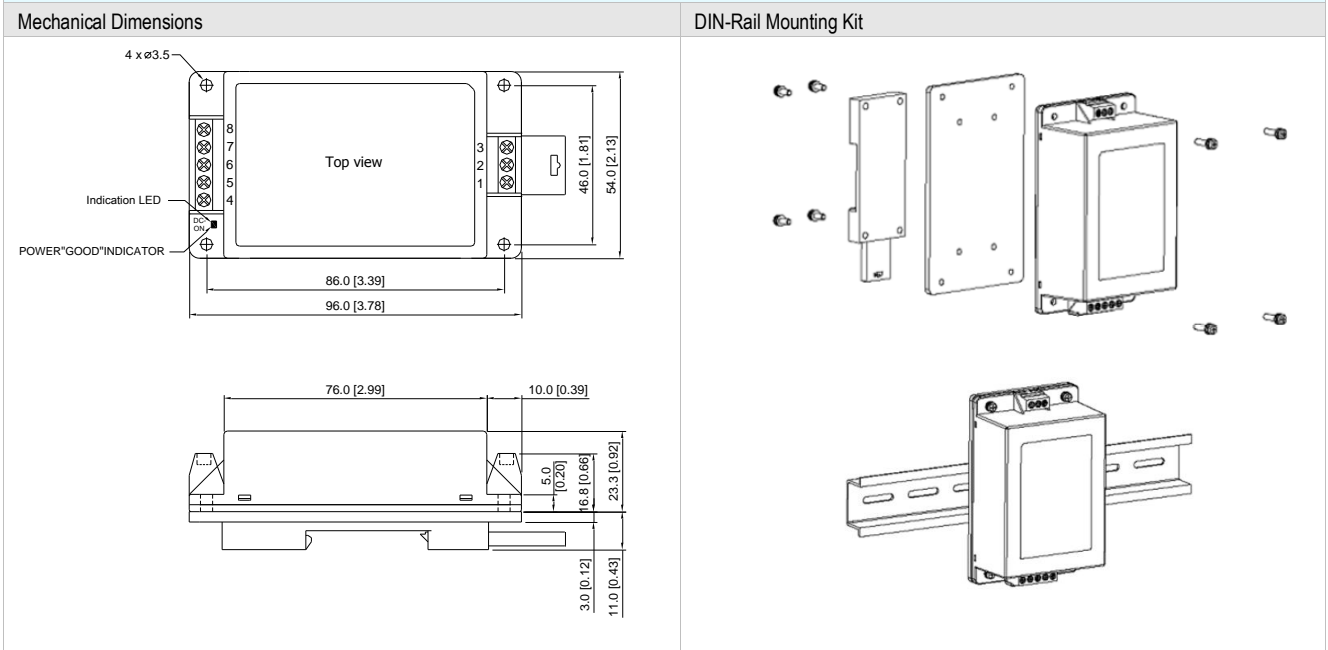

**Physical Characteristics**

|               |  |
|---------------|--|
| Case Size     | : 96.0x54.0x23.3mm (3.78x2.13x0.92 inches)       |
| Case Material | : Plastic resin (flammability to UL 94V-0 rated) |
| Weight        | : 166g   |

**Order Code Table**

| Standard       | With DIN Rail Mounting by two Order Code |           |
|----------------|--|-----------|
| MOWI20-24S051C | MOWI20-24S051C                           | AC-DIN-01 |
| MOWI20-24S12C  | MOWI20-24S12C                            | AC-DIN-01 |
| MOWI20-24S24C  | MOWI20-24S24C                            | AC-DIN-01 |
| MOWI20-24S48C  | MOWI20-24S48C                            | AC-DIN-01 |
| MOWI20-48S051C | MOWI20-48S051C                           | AC-DIN-01 |
| MOWI20-48S12C  | MOWI20-48S12C                            | AC-DIN-01 |
| MOWI20-48S24C  | MOWI20-48S24C                            | AC-DIN-01 |
| MOWI20-48S48C  | MOWI20-48S48C                            | AC-DIN-01 |

## Test Setup

### Peak-to-Peak Output Noise Measurement Test

Scope measurement should be made by using a BNC socket, measurement bandwidth is 0-20 MHz. Position the load between 50 mm and 75 mm from the DC/DC Converter.

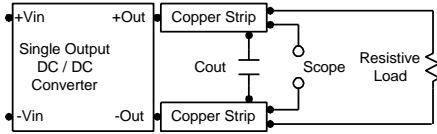

## Technical Notes

### Remote On/Off

Positive logic remote on/off turns the module on during a logic high voltage on the remote on/off pin, and off during a logic low. To turn the power module on and off, the user must supply a switch to control the voltage between the on/off terminal and the -Vin terminal. The switch can be an open collector or equivalent. A logic low is 0V to 1.2V. A logic high is 3.5V to 12V. The maximum sink current at the on/off terminal (Pin 1) during a logic low is -100 $\mu$ A.

### Overload Protection

To provide hiccup mode protection in a fault (output overload) condition, the unit is equipped with internal current limiting circuitry and can endure overload for an unlimited duration.

### Overvoltage Protection

The output overvoltage clamp consists of control circuitry, which is independent of the primary regulation loop, that monitors the voltage on the output terminals. The control loop of the clamp has a higher voltage set point than the primary loop. This provides a redundant voltage control that reduces the risk of output overvoltage. The OVP level can be found in the output data.

### Input Source Impedance

The power module should be connected to a low ac-impedance input source. Highly inductive source impedances can affect the stability of the power module.

In applications where power is supplied over long lines and output loading is high, it may be necessary to use a capacitor at the input to ensure startup.

Capacitor mounted close to the power module helps ensure stability of the unit, it is recommended to use a good quality low Equivalent Series Resistance (ESR < 1.0  $\Omega$  at 100 KHz) capacitor of a 10 $\mu$ F for the 24V and 48V devices.

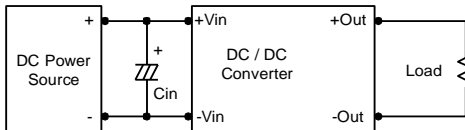

### Output Ripple Reduction

A good quality low ESR capacitor placed as close as practicable across the load will give the best ripple and noise performance. To reduce output ripple, it is recommended to use 4.7 $\mu$ F capacitors at the output.

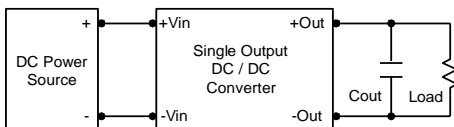

### Maximum Capacitive Load

The MOWI20C series has limitation of maximum connected capacitance at the output. The power module may be operated in current limiting mode during start-up, affecting the ramp-up and the startup time. The maximum capacitance can be found in the data sheet.

### Thermal Considerations

Many conditions affect the thermal performance of the power module, such as orientation, airflow over the module and board spacing. To avoid exceeding the maximum temperature rating of the components inside the power module, the case temperature must be kept below 95°C. The derating curves are determined from measurements obtained in a test setup.

